

# Specification

## 规格书

Customer Name :

客户名称: \_\_\_\_\_

Customer P/N:

客户品名:

Factory P/N: \_\_\_\_\_

公司品名: 2532CW/26-28LM/RA70

Sending Date:

送样日期: \_\_\_\_\_

规格参数 Specification parameter			
Luminous Flux 光通量	Forward Voltage 正向电压	color temperature 色温	Color Rendering Index 显色性指数
23-28LM	3.0-3.4V	6000-6500K	RA70

Client approval 客户审核			Desili approval 迪司利审核		
Approval 核准	Audit 确认	Confirmation 制作	Approval 核准	Audit 确认	Confirmation 制作
<input type="checkbox"/> Qualified 接受		<input type="checkbox"/> Disqualifide 不接受		Date: 日期:	

# 2532CW/26-28LM/RA70

## Features(特征)

- PLCC-6 Package.(PLCC-6封装)
- Extremely wide viewing angle. (宽的发光角度)
- Suitable for all SMT assembly and solder process. (适用于所有的 SMT 组装和焊接工艺)
- Available on tape and reel. (适用于载带及卷轴)
- Moisture sensitivity level: Level 4. (防潮等级 Level 4)
- Package:26000pcs/reel.(包装每卷 26000PCS)
- RoHS compliant. (RoHS 认证)



## Description (描述)

The White LED which was fabricated using a blue chip and the phosphor  
白光 LED 由蓝光芯片与荧光粉激发而成

**ATTENTION**  
OBSERVE PRECAUTIONS  
FOR HANDLING  
ELECTROSTATIC  
DISCHARGE  
SENSITIVE  
DEVICES

注意：操作时应注意静电敏感  
释放设备装置

## Applications (应用)

- Optical indicator (光学指示)
- Indoor display (室内显示)
- Automotive lighting (汽车照明)
- Backlight for LCD, switch and Symbol, display  
(LCD 背光、转换器, 开关和标志, 显示器等)
- Tubular light application (用于日光灯管)
- General use (一般应用)

## Package Dimensions (封装尺寸)

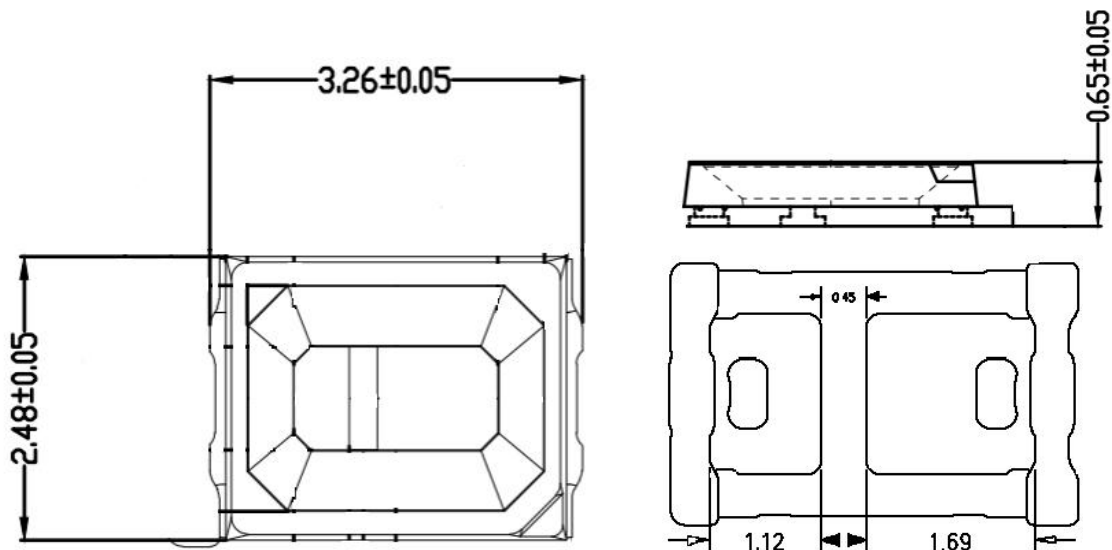

### Notes: (备注)

1. All dimension units are millimeters. (所有标注尺寸单位为毫米)
2. All dimension tolerance is ±0.15mm unless otherwise noted. (除特别标注外, 所有尺寸允许公差 ±0.15mm)

## 2532CW/26-28LM/RA70

### Selection Guide (选择指南)

Part No (型号)	Chip Materials (芯片材料)	Chips Size (芯片大小)	Lens Type (胶体类型)
2532CW/26-28LM/RA70	InGaN	-----	Yellow Diffused

### Mass Production list (批量生产目录)

分光测试参数: Ta=25°C

Part NO 型号	CCT (K) MIN	CCT (K) TYP	CCT (K) MAX	Φ (LM) MIN	Φ (LM) MAX	Test conditions 测试条件
2532CW/26-28/RA70	6000	---	6500	23	--	IF=60 MA

应用参数: Ta=25°C

Part NO 型号	CCT (K) MIN	CCT (K) TYP	CCT (K) MAX	Φ (LM) MIN	Φ (LM) MAX	Cueernt use is recommended (建议使用 电流)
2532CW/26-28/RA70	/	6400	/	/	/	IF=60 MA 以内

### Electrical / Optical Characteristics at Ta=25°C 电性与光学特性

Parameter (参数)	Symbol (符号)	Min (最小值)	Typ (平均值)	Max (最大值)	Units (单位)	Test Condition (测试条件)
Forward Voltage (正向电压)	VF	3.0	--	3.4	V	IF=60mA
Vietwing Angle (角度)	2Ø1/2	--	120	--	deg	IF=60mA
Color Rendering Index (显示指数)	Ra	--	70	--	--	IF=60mA
Reverse Cueurnt (反向电流)	IR	--	--	2	µA	VR=7V

Note:(备注)

- 201/2 is the angle from optical centerline where the luminous intensity is 1/2 the optical centerline value.  
201/2 是半值角, 指光强是光学中心线光强的 1/2 处到光学中心线的角度
- The above luminous flux measurement allowance tolerance is ±10%.  
上述发光通量的测试允许公差为±10%
- The above Color Rendering Index measurement allowance tolerance is : ±2  
以上显色性指数的测试允许公差为±2
- The above forward voltage measurement allowance tolerance is ±0.1V.  
以上所示电压测量误差±0.1V
- The above color coordinates measurement allowance tolerance is ±0.003.  
以上所示坐标测量误差±0.003

## 2532CW/26-28LM/RA70

### Absolute Maximum Ratings at Ta=25°C

### 绝对最大额定值

Parameter (参数)	Symbol (符号)	Rating (值)	Units (单位)
Power Dissipation (功耗)	Pd	200	mW
Forward Current (正向电流)	IF	60	MA
Peak Forward Current [1] (峰值正向电流)	IFP	90	MA
Reverse Voltage (反向电压)	VR	7	V
Electrostatic Discharge (HBM) (静电)	ESD	2000	V
Operating Temperature (操作温度)	Topr	-40 ~ +85	℃
Storage Temperature (保存温度)	Tstg	-40 ~ +100	℃
Thermal Resistance (Junction / Soldering point) 热阻	Rthj-s	30	℃/W
Junction Temperature 结温	Tj	110	℃

Note: (备注)

1. 1/10 Duty cycle, 0.1ms pulse width. (脉宽 0.1ms, 周期 1/10)

# 2532CW/26-28LM/RA70

## Typical optical characteristics curves 典型光学特性曲线

Soldering Temperature vs. Forward Current  
焊盘温度与正向电流特性曲线

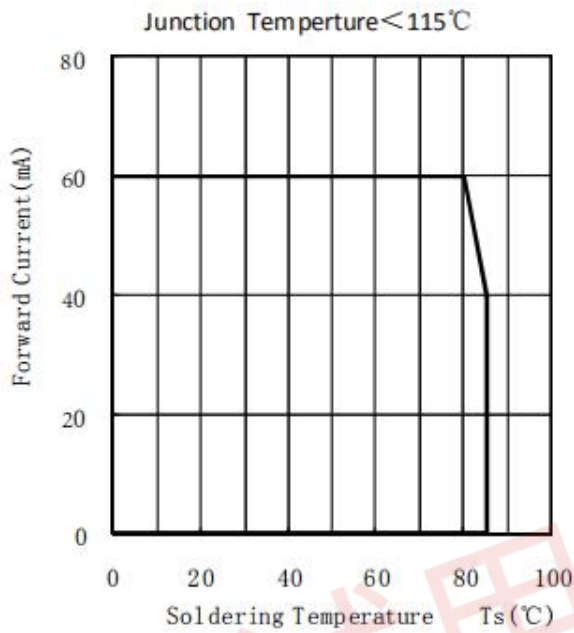

Forward Current VS. Relative Intensity  
正向电流与相对光强特性曲线

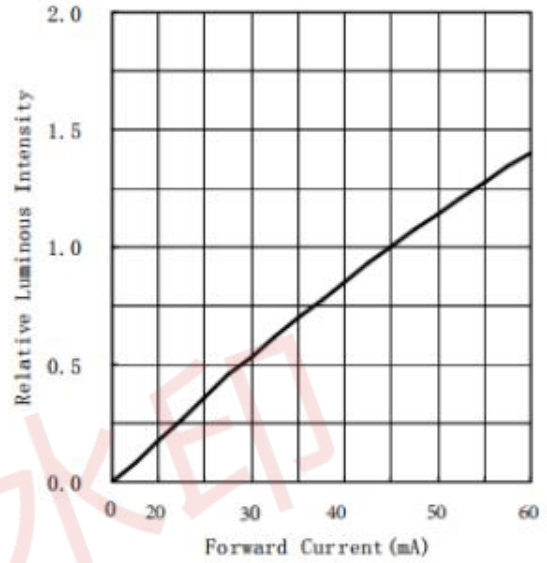

Forward Voltage VS. Forward Current  
正向电压与正向电流特性曲线

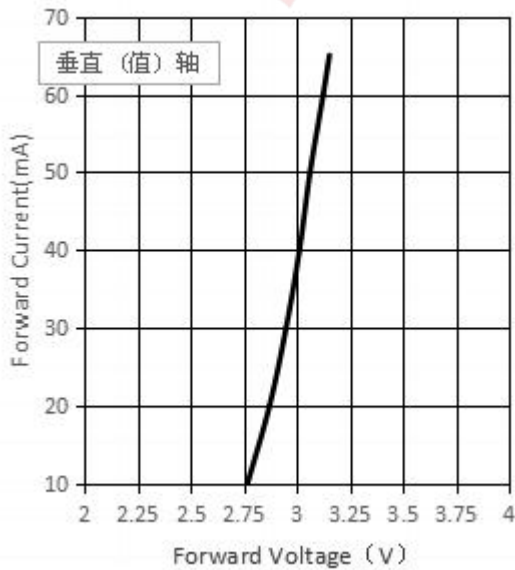

Ambient Temperature VS. Relative Intensity  
环境温度与相对光强特性曲线

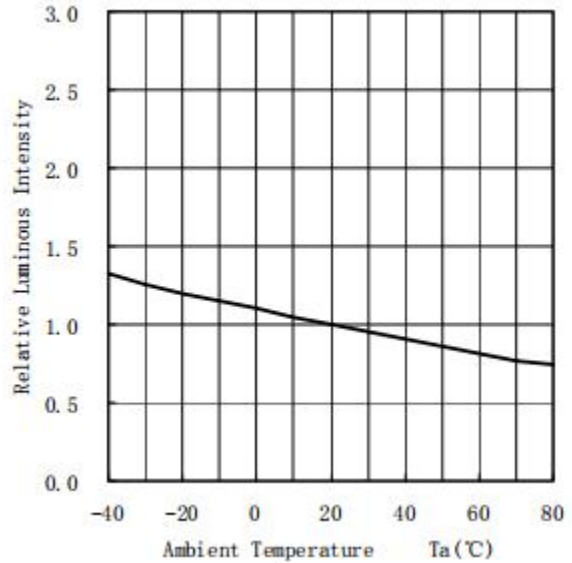

# 2532CW/26-28LM/RA70

## Typical optical characteristics curves 典型光学特性曲线

Relative spectral emission 相对光谱分布特性曲线

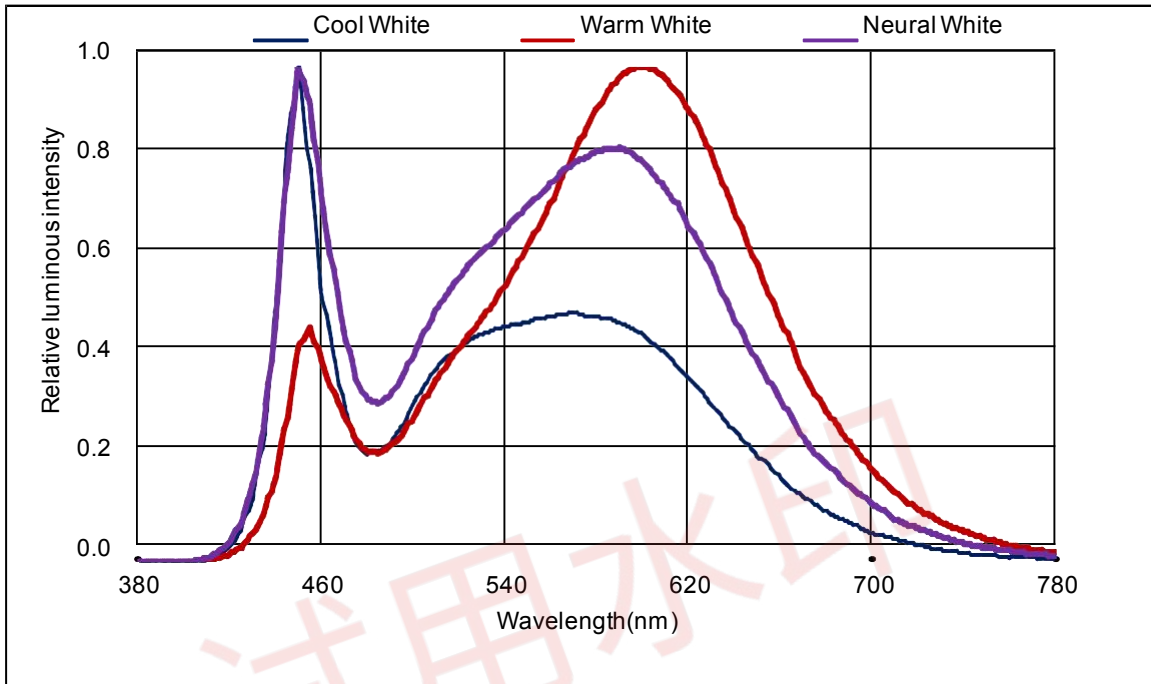

Radiation diagram 辐射图特性曲线

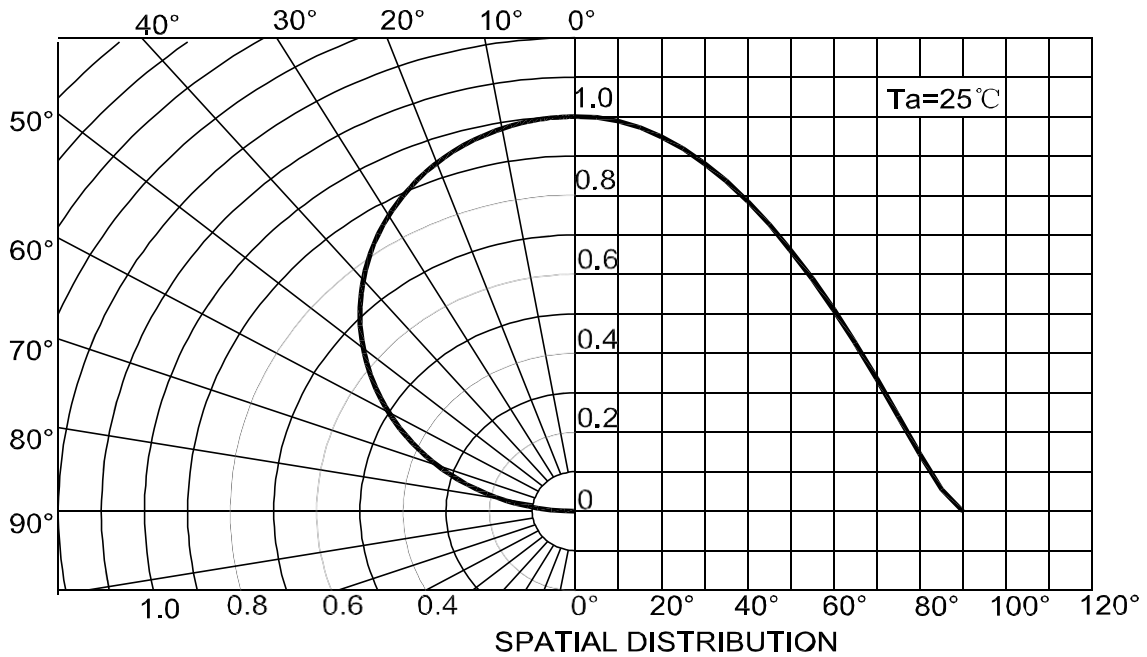

## 2532CW/26-28LM/RA70

### Reliability Test Items And Conditions 信赖性测试项目及条件

Test Items 项目	Ref. Standard 参考标准	Test Condition 测试条件	Time 时间	Quantity 数量	Ac/Re 接收/拒收
Reflow 回流焊	JESD30-B106	Temp:250°C max T=10 sec	3 times.	30Pcs.	0/1
Temperature Cycle 温度循环	JESD30-A104	100°C±5°C 30 min. ↑↓5 min -40°C±5°C 30 min.	100 Cycles	30Pcs.	0/1
High Temperature Storage 高温保存	JESD30-A103	Temp:100°C±5°C	1000Hrs.	30Pcs.	0/1
Low Temperature Storage 低温保存	JESD30-A119	Temp:-40°C±5°C	1000Hrs.	30Pcs.	0/1
Life Test 常温通电	JESD30-A108	Ta=25°C±5°C IF=60mA	1000Hrs.	30Pcs.	0/1
High Temperature High Humidity Life Test 高温高湿通电	JESD30-A101	85°C±5°C/ 85% RH IF=60mA	500Hrs.	30Pcs.	0/1

### Criteria For Judging Damage 失效判定标准

Test Items 项目	Symbol 符号	Test Condition 测试条件	Criteria For Judgement 判定标准	
			Min. 最小	Max. 最大
Forward Voltage 正向电压	VF	IF=60mA	--	3.4
Reverse Current 反向电流	IR	VR = 7V	--	2
Luminous Flux 光通量	Im	IF=60mA	21	--

U.S.L: Upper standard level 规格上限

L.S.L: Lower standard level 规格下限

\*The technical information shown in the data sheets are limited to the typical characteristics and circuit examples of the referenced products. It does not constitute the warranting of industrial property nor the granting of any license.

数据工作表中所示的技术信息仅限于典型特征和电路实例引用的产品。它既不构成工业特性的保证,也不构成任何许可的授权

## SMT Reflow Soldering Instructions SMT 回流焊说明, 建议最高温度不超过 245 度

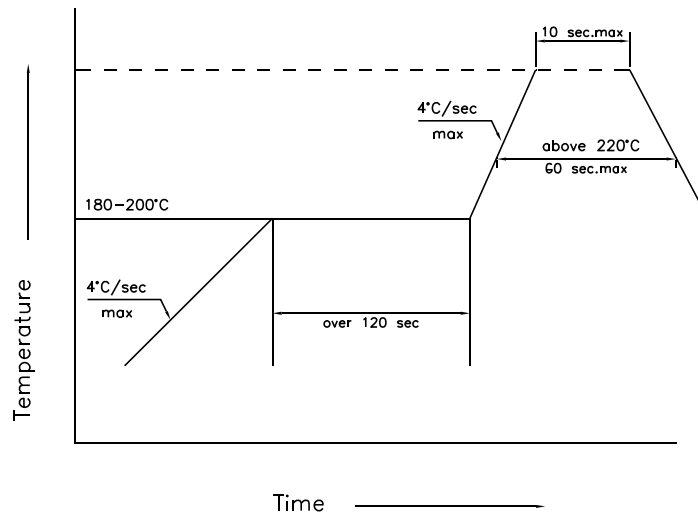

1. Reflow soldering should not be done more than two times. 回流焊不可以做两次以上
2. When soldering, do not put stress on the LEDs during heating  
当焊接时, 不要在材料受热时用力压胶体表面

### Soldering iron 烙铁焊接

1. When hand soldering, keep the temperature of iron below less 300°C less than 3 seconds  
当手工焊接时, 烙铁的温度必须小于 300°C, 时间不可超过 3 秒
2. The hand solder should be done only one times  
手工焊接只可焊接一次

### Repairing 修补

Repair should not be done after the LEDs have been soldered. When repairing is unavoidable, a double-head soldering iron should be used (as below figure). It should be confirmed in advance whether the characteristics of LEDs will or will not be damaged by repairing. LED 回流焊后不应该修复, 当修复是不可避免时, 必须使用双头烙铁 (如下图), 但必须事先确认此种方式会或不会损坏 LED 本身的特性。

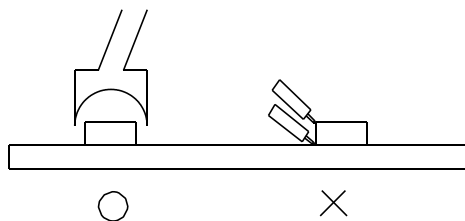

### Cautions 注意事项

The encapsulated material of the LEDs is silicone. Therefore the LEDs have a soft surface on the top of package. The pressure to the top surface will be influence to the reliability of the LEDs. Precautions should be taken to avoid the strong pressure on the encapsulated part. So when use the picking up nozzle, the pressure on the silicone resin should be proper. LED 封装为硅胶, 故 LED 胶体表面较软, 用力按压胶体表面会影响 LED 可靠性, 因此应有预防措施避免在封装的零件上的强大压力, 当使用吸嘴时, 胶体表面的压力应是恰当的。

## 2532CW/26-28LM/RA70

### Handling Precautions 处理防备措施

Compare to epoxy encapsulant that is hard and brittle, silicone is softer and flexible. Although its characteristic significantly reduces thermal stress, it is more prone to damage by external mechanical force. As a result, Special handling precautions must be observed during assembling using silicone encapsulated LED products, Failure to comply might leads to damage and premature failure of the LED. 相对环氧树脂较脆较硬而言，硅胶封装较柔软且有弹性，虽然它的特性大大减少了热应力，但易受机械外力损坏，因此 在手工处理方面须要对硅胶封装材料做预防措施，若未按要求操作，可能会导致 LED 损坏和光衰

1.Handle the component along the side surface by using forceps or appropriate tools; do not directly touch or Handle the silicone lens surface, it may damage the internal circuitry. 通过使用适当的工具从材料侧面夹取，不可直接用手或尖锐金属压胶体表面，它可能会损坏内部电路

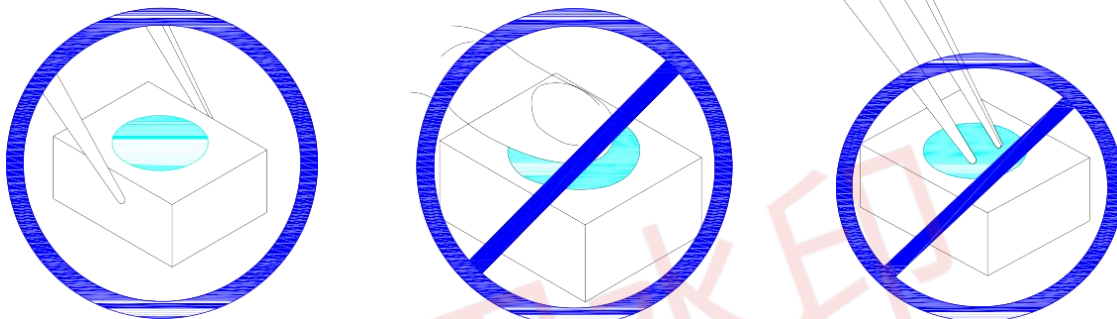

2.The outer diameter of the SMD pickup nozzle should not exceed the size of the LED to prevent air leaks. The inner diameter of the nozzle should be as large as possible. A pliable material is suggested for the nozzle tip to avoid scratching or damaging the LED surface during pickup. The dimensions of the component must be accurately programmed in the pick-and-place machine to insure precise pickup and avoid damage during production. 为防止气压泄漏，SMD 吸咀外径不可以超过 LED 尺寸，吸咀内径尺寸应尽可能大，吸咀顶端材质建议采用柔软材料以防在吸取期间刮伤或损坏 LED 胶体表面，元件的尺寸必须在取放机里准确的编程好，以确保精确的吸取和避免生产过程中的损害



3.Do not stack together assembled PCBs containing LEDs. Impact may scratch the silicone lens or damage the internal circuitry 不可将模组材料堆积在一起，它可能会损坏内部电路

4.Not suitable to operate in acidic environment, PH<7  
不可用在 PH<7 的酸性场所

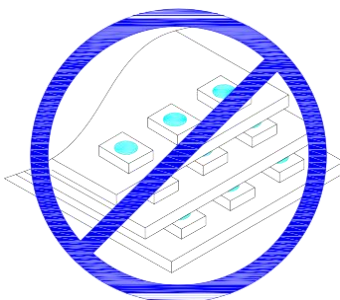

5.LED operating environment and sulfur element composition cannot be over 100PPM in the LED mating usage material.

LED 工作环境及与 LED 适配的材料中硫元素及化合物成份不可超过 100PPM

6. When we need to use external glue for LED application products, please make sure that the external gluematches the LED packaging glue. Additionally ,as most of LED packaging glue is silica gel, and it has strong Oxygen permeability as well as strong moisture permeability; in order to prevent external material from getting into the inside of LED, which may cause the malfunction of LED, the single content of Bromine element is required to be less than 900PPM,the single content of Chlorine element is required to be less than 900PPM,the total content of Bromine element and Chlorine element in the external glue of the application products is required to be less than 1500PPM 当我们需要使用外封胶涂抹 LED 产品时, 应确保外封胶与 LED 封装胶水相匹配, 因为大多数 LED 的封装胶水为硅胶, 它有较强的氧化性和较强的吸湿性, 必须防止外封材质进入 LED 内部以造成 LED 的损伤, 单一的溴元素含量要求小于 900PPM, 单一氯元素含量要求小于 900PPM, 在涂抹 LED 产品时要求外封胶溴元素与氯元素总含量必须小于 1500PPM

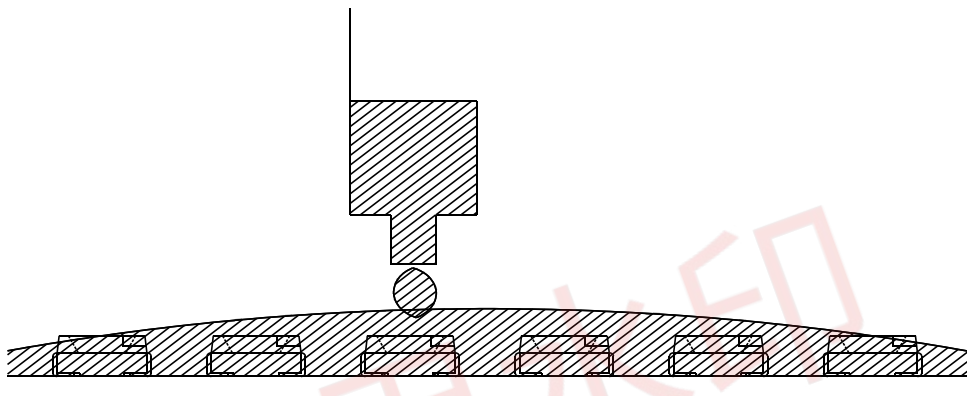

### Storage Condition 储存条件

#### Before opening the package 打开包装袋前:

1. The LEDs can be preserved for 1 year in condition of temperature no more than 30℃ and humidity no more than 60%RH. Recommended for moisture-proof foil bag with desiccant packaging methods and stored in the constant temperature and humidity box.  
在温度不超过30℃及湿度不超过60%RH 条件下, LED 可以保存一年, 建议采用带干燥剂的防潮铝箔袋的包装方式, 存放在恒温恒湿箱中
2. Stored for more than 7 days, next time must be dehumidification, the dehumidification conditions is 75℃ with 12hours.  
存放时间超过7 天的, 下次使用时必须进行除湿, 除湿条件为75℃ 12 小时

#### After opening the package 打开包装后:

1. The SMD LEDs should be run out with 24hours in condition of temperature no more than 30℃ and humidity nomore than 60%RH. The rest products should be pressurized in vacuum condition with desiccants. Stored for more than 7 days, next time also must be dehumidification, the dehumidification conditions is 75℃ with 12hours  
开封后, LED 在≤30℃,≤60%RH 相对湿度的条件下, 24 小时内完成贴片作业, 未用完的产品重新真空密封, 并放置在一个密封容器中, 同时必须使用干燥剂. 存储超过7 天, 下次使用时同样需要除湿操作, 除湿条件为75℃ 12 小时
2. The sealed storage products stock in the drying cabinet more for than one month, then must be dehumidified before used, and the dehumidified conditions is 75℃ 24 hours.  
密封的产品在干燥箱中存储超过1个月的, 须经过深度除湿作业才能上线, 除湿条件: 75℃24小时
3. If the product does not vacuum sealed packaging, and in the air for more than 72 hours, this product must be removed from the tape of reel and put into the steel plate to dehumidify with 150℃ 2 hours, then could ensure the quality of the product after the soldering operation.  
如果产品没有真空包装密封保存, 且在空气中放置超过72小时, 此产品必须从载带中拆出, 放入钢盘进行150℃2小时的除湿, 之后进行回流焊作业才能保证产品质量

# 2532CW/26-28LM/RA70

Label 标签

Φ: Luminous Flux 光通量

VF: Forward voltage rank 电压等级

CCT: Correlated Colour Temperature 相关色温

## Tape Specifications (Units : mm) 载带规格 (单位: mm)

ITEM	W	AO	BO	KO	E	F	DO	D1	P0	P1	P2	T	
DIM	8.00	2.78	3.56	0.83	1.75	3.50	1.60	1.10	4.00	4.00	2.00	0.20	PCS/R
TOLE	+0.10 -0.10	+0.10 -0.10	+0.10 -0.10	+0.10 -0.10	+0.10 -0.10	+0.05 -0.05	+0.10 -0.10	+0.10 -0.10	+0.10 -0.10	+0.10 -0.10	+0.10 -0.10	+0.05 -0.05	M/R

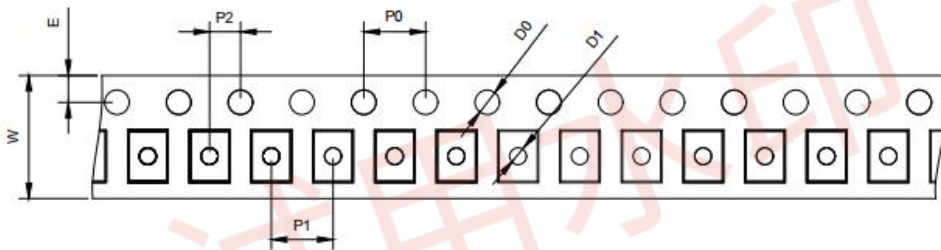

## Reel Dimensions

卷轴尺寸

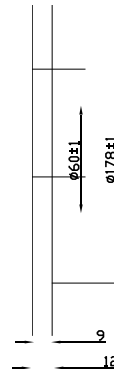
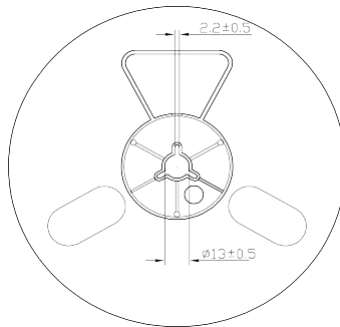

## Moisture Resistant Packaging 防潮带包装

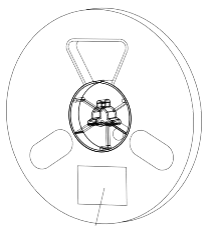

Lable

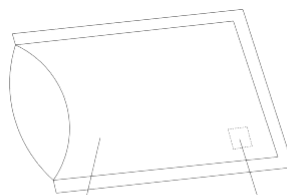
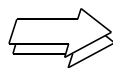

Aluminum moisture-proof bag

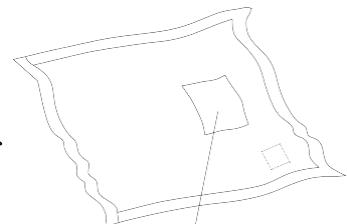
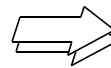

Desiccant

Lable

Note: The tolerances unless mentioned is ±0.1mm , Unit: mm

注: 标注公差为 ±0.1mm · 单位: mm