

產品規格书  
Production Specification

承認書

Samples approval sheet

客戶名稱 (Customer name) \_\_\_\_\_

元件名稱 (Production name): 貼片發光二極體 \_\_\_\_\_

型號 (Model): 3030RGB -0.6W \_\_\_\_\_

編號 (Part number): 1902001 \_\_\_\_\_

日期 (Date): 2019-2-12 \_\_\_\_\_

SMD LED			
編制 Prepared by	審核 Checked by	核准 Approved by	市場部 Market Dept.

一、

客戶確認 CUSTOMER CONFIRMATION		
確認 Confirmed by	審核 Checked by	核准 Approved by

# SMD LED

## 3030 系列 LED 贴片灯

产品型号 (Product Type): 3030RGB-0.6W

### Package Dimensions (封装尺寸)

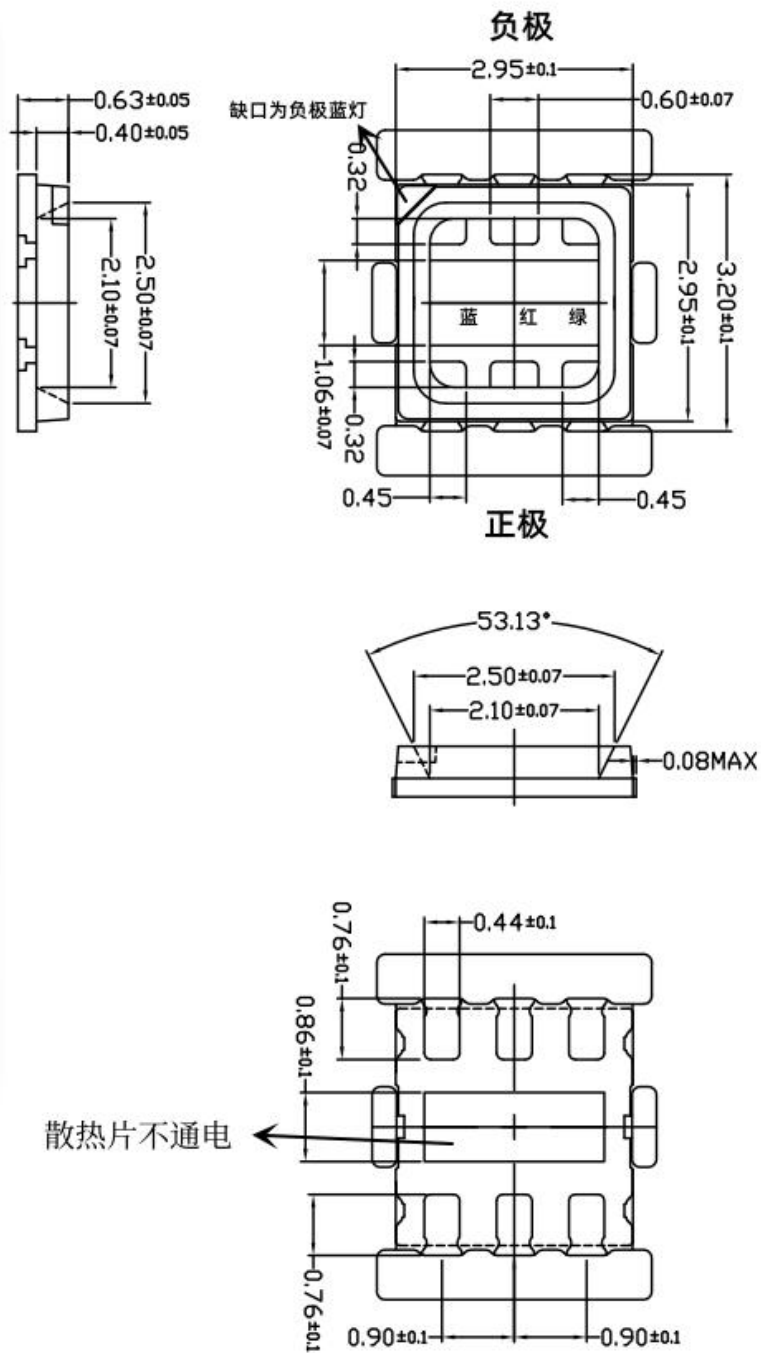

备注 (NOTES): 缺口为蓝负极 中间红

1、 所有尺寸单位为毫米

# SMD LED

产品型号 (Product Type): 3030RGB-0.6W

## 极限参数 Absolute maximum ratings (Ta=25°C)

参数 Parameter	符号 Symbol	数值 Value	单位 Unit
正向电流 Forward current	If	60	mA
反向耐压 Reverse voltage	Vr	5	V
工作环境温度 Operating temperature range	Top	-25~+80	°C
贮藏温度 Storage temperature range	Tstg	-30~+85	°C

## 光电特性 Electro-Optical characteristics (TA=25°C)

参数 Parameter	测试条件 Test Condition	符号 Symbol	颜色	数值 Value			单位 Unit
				Min	Typ	Max	
色温 Color Temperature	If=60mA	CCT	--	--	--	--	K
正向电压 Forward voltage	If=60mA	Vf	R G B	2.0 3.0 3.0	--	2.4 3.2 3.2	V
光通量 luminous flux	If=60mA	φ	R G B	7 18 3	--	10 23 6	LM
视角 Viewing angle at 50% IV	If=60mA	2θ1/2	R G B	--	120	--	Deg
主波长 Dominant wavelength	If=60mA	λd	R G B	620 520 455	--	625 525 462	nm
反向电流 Reverse current	Vr=5V	Ir	R G B	--	5	--	μA
显色性指数 Color Rendering Index	If=60mA	CRI	--	--	--	--	Ra

# SMD LED

产品型号 (Product Type): 3030RGB-0.6W

典型的光电特性角度图

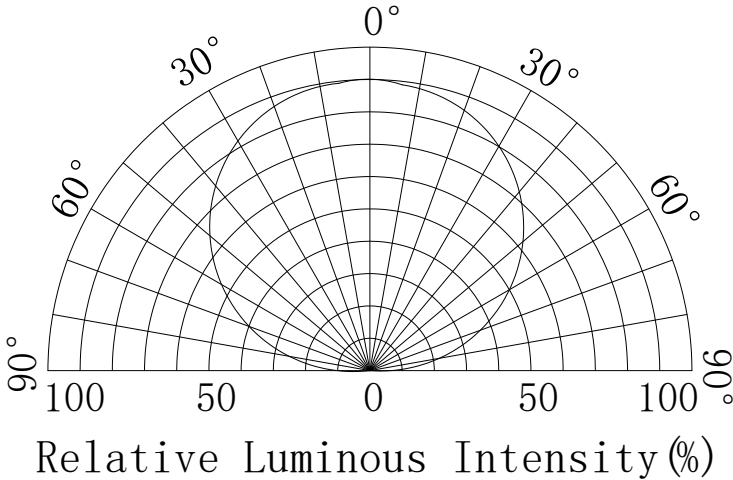

# SMD LED

产品型号 (Product Type): 3030RGB-0.6W

典型的光电特性曲线图表 Typical photo-electricity characteristic curve chart

## 失效判定标准 Criteria For Judging Damage

测试项目	符号	测试条件	判定标准
正向电压 Forward Voltage	$V_F$	$I_F=I_{FT}$	初始值 $\pm 10\%$ Initial Data $\pm 10\%$
反向电流 Reverse Current	$I_R$	$V_R=5V$	$I_R \leq 10\mu A$
光强 Luminous Intensity	$I_V$	$I_F=I_{FT}$	平均 $I_V$ 衰减 $\leq 30\%$ , 单个平均 $I_V$ 衰减 $\leq 50\%$ Average $I_V$ degradation $\leq 30\%$ Single LED $I_V$ degradation $\leq 50\%$
耐焊接热 Resistance to Soldering Heat	--	--	材料无内部裂痕、无材料间爆裂、剥离、无死灯 Material without internal cracks, no material between stripped, no deaded light.

\*数据工作表中所示的技术信息仅限于典型特征和电路实例引用的产品.它既不构成工业特性的保证,也不构成任何许可的授权

The technical information shown in the data sheets are limited to the typical characteristics and circuit examples of the referenced products. It does not constitute the warranting of industrial property nor the granting of any license.

QC-SMD LED

# SMD LED

## 可靠性实验项目 Test items and results of reliability

类别 Type	测试项目 Test item	参照标准 Standard	测试条件 Test Conditions	备注 Note	数量 Quantity	不良数量 Number of Damaged
Environmental Sequence	高低温循环 Temperature Cycle	JIS C 7021 (1977)A-4	-25°C 30min ↑↓5min 80°C 30min	100 cycle	22	0
	热冲击 Thermal Shock	MIL-SLD-107D	-25°C 15min ↑↓5min 80°C 15min	50 cycle	22	0
	高湿度热循环 High Humidity Heat Cycle	JIS C 7021 (1977)A-5	30°C (<=> 65°C 90%RH 24hrs/1cycle	10 cycle	22	0
	高温存储 High Temperature Storage	JIS C 7021 (1977)B-10	T <sub>a</sub> =80°C	1000hrs	22	0
	高温高湿存储 Humidity Heat Storage	JIS C 7021 (1977)B-11	T <sub>a</sub> =60°C RH=90%	1000hrs	22	0
	低温存储 Low Temperature Storage	JIS C 7021 (1977)B-12	T <sub>a</sub> =-30°C	1000hrs	22	0
Operation Sequence	常温寿命测试 Life Test	JIS C 7035 (1985)	T <sub>a</sub> =25°C I <sub>F</sub> =60mA	1000hrs	22	0
	高温高湿寿命测试 High Humidity Heat Life Test	*	60°C RH=90% I <sub>F</sub> =60mA	500hrs	22	0
	低温寿命测试 Low Temperature Life Test	*	T <sub>a</sub> =-25°C I <sub>F</sub> =60mA	1000hrs	22	0

\*请参考可靠性测试标准规范。Refer to reliability test standard specification for in this line.

# SMD LED

产品型号 (Product Type): 3030RGB-0.6W

## 焊接指导 Guideline for Soldering

1、回流焊接: 推荐以下无铅回流焊接温度图进行。

**Reflow Soldering:** Use the conditions shown in the under Figure of Pb-Free Reflow Soldering.

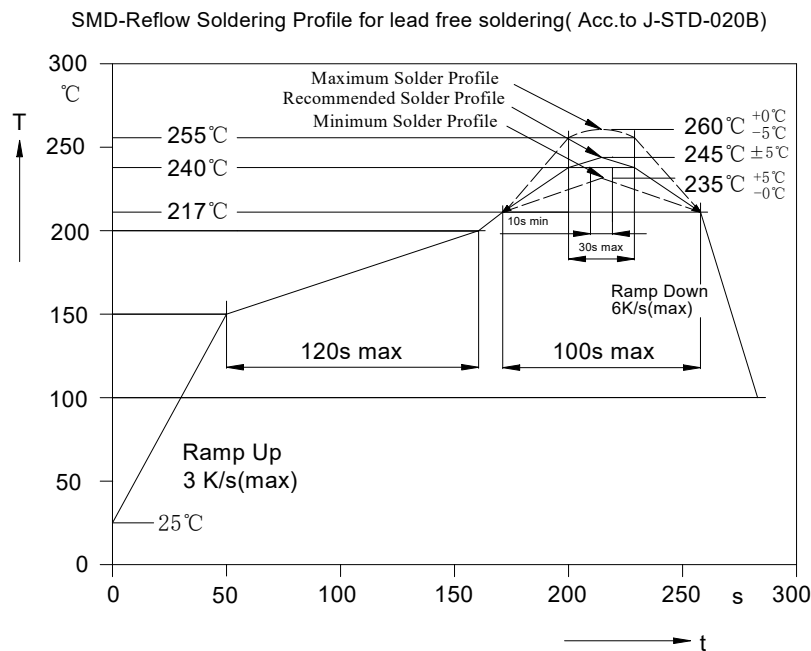

**Remark:** If not lead free soldering, the recommended solder profile is 230°C and max solder profile is 245°C.

2、使用烙铁人手焊接 Hand Soldering

1)、推荐使用低功率于 20W 的烙铁, 焊接时烙铁的温度必须保持在 360°C 以下, 且每个电极只能进行一次焊接, 每次焊接的持续时间不得超过 3 秒。

A soldering iron of less than 20W is recommended to be used in Hand Soldering Please keep the temperature of the soldering iron under 360°C while soldering Each terminal of the LED is to go for less than 3 second and for onetime only.

2)、人手焊接过程中的不慎操作易引起 LED 产品的损坏, 应当小心谨慎。

Be careful because the damage of the product is often started at the time of the hand soldering.

3、清洗 Cleaning

1)、在焊接后推荐使用酒精进行清洗, 在温度不高于 30°C 的条件下持续 3 分钟, 不高于 50°C 的条件下持续 30 秒, 使用其他类似溶剂清洗前, 请先确认使用的溶剂不会对 LED 的封装和环氧树脂造成损伤。

It is recommended that alcohol be used as a solvent for cleaning after soldering. Cleaning is to go under 30°C for 3 minutes or 50°C for 30 seconds. When using other solvents, it should be confirmed beforehand whether the solvents will dissolve the package and the resin or not.

2)、超声波清洗也是有效的方法, 一般最大功率不应超过 300W, 否则可能对 LED 造成损伤, 请根据具体的情况预先测试清洗条件是否会对 LED 造成损伤。

Ultrasonic cleaning is also an effective way for cleaning. But the influence of Ultrasonic cleaning on LED depends on factors such an ultrasonic power. Generally, the ultrasonic power should not be higher than 300W. Before cleaning, a pre-test should be done to confirm whether any damage to LEDs will occur.

# SMD LED

产品型号 (Product Type): 3030RGB-0.6W

## 编带和包装 Tape and Packaging

### 1、带盘 Tape leader and reel

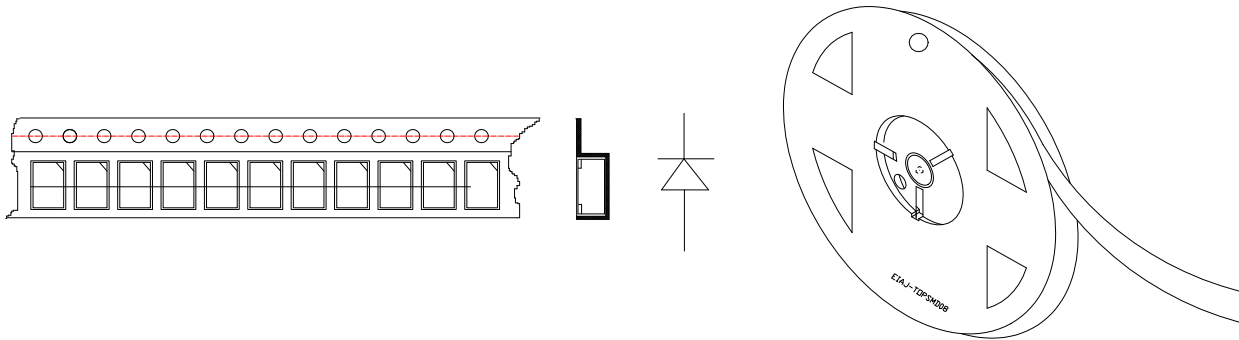

### 2、防潮袋包装 Moisture Resistant Packaging

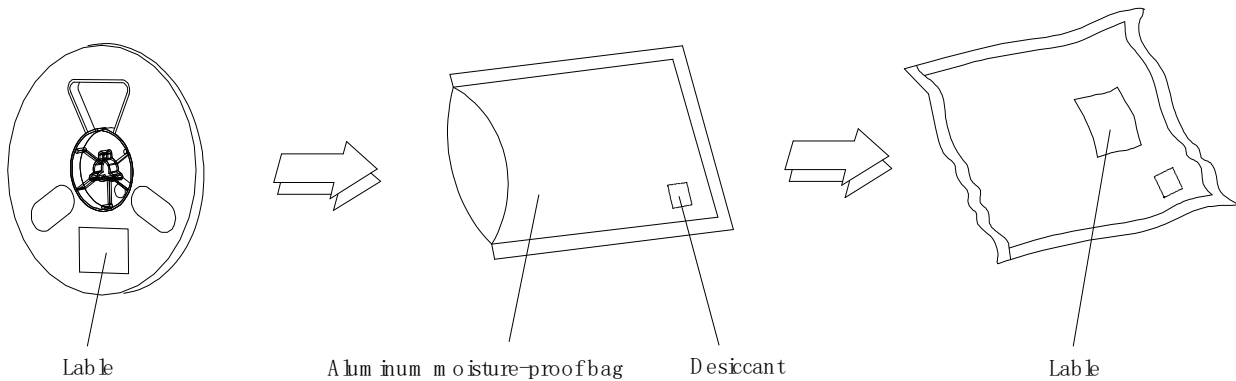

### 3、注意事项 Cautions

1)、LED 封装为硅胶，故 LED 胶体表面较软，用力按压胶体表面会影响 LED 可靠性，因此应有预防措施避免在封装的零件上的强大压力，当使用吸嘴时，胶体表面的压力应是恰当的。

The encapsulated material of the LEDs is silicone. Therefore the LEDs have a soft surface on the top of package. The pressure to the top surface will be influence to the reliability of the LEDs. Precautions should be taken to avoid the strong pressure on the encapsulated part. So when use the picking up nozzle, the pressure on the silicone resin should be proper.

2)、SMD 吸嘴的外径不应超过 LED 的尺寸以避免漏气。吸嘴的内径应尽可能大。吸嘴头建议使用柔软的材料以避免 LED 硅胶表面划伤或损坏。

The outer diameter of the SMD pickup nozzle should not exceed the size of the LED to prevent air leaks. The inner diameter of the nozzle should be as large as possible. pliable material is suggested for the nozzle tip to avoid scratching or damaging the LED surface during pickup.

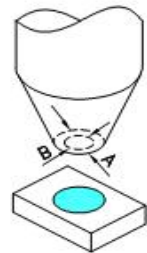

# SMD LED

产品型号 (Product Type): 3030RGB-0.6W

## 关于贴片 LED 的注意事项:

- 1、回流焊温度曲线为 (6 温区有铅锡熔点 186 度) 140—160—180—200—220—200 (7 温区有铅锡熔点 186 度) 120—140—160—180—200—220—200 (8 温区无铅) 130—150—170—190—210—230—245—220 (7 温区无铅) 150—170—190—210—230—245—220 须达到总时间 6 分到 8 分。温度平滑上升, 有回温区。
- 2、回流焊速度为每分钟 45-60 厘米。(速度慢相当于是除湿不足的有效补充) 可以慢不可快。5 温区 25, 6 温区 25—30, 7 温区 30—40, 8 温区 40—50。(相当重要)
- 3、在贴灯之前撕开袋子, 用烤箱 70-75 度除湿 24 小时以上, 除湿之后立即使用, 建议从热烤箱里面直接拿出来用, 除湿之后不可以放置于空气中过久, 容易再度吸湿, LED 超过 10 天未使用, 须除湿 48 小时以上。做无铅高温锡时, 必须除湿 48 小时以上。贴片除湿是过回流焊脱胶死灯的关键所在。
- 4、贴片硅胶是硬的过回流焊时要越快越好, 建议使用时除湿后先拆 2K 试样如果没问题再用后面的。
- 5、开始生产的时候, 必须做首检, 做完发现坏完了的情况本公司一律不承担任何超出总灯量 10% 的 LED 灯。
- 6、贴片前, 请注意分箱号使用, 防止混色, 造成色差。
- 7、以下情况造成 LED 发黑变色。锡膏含硫, 磷化合物, 溴化物, 肥皂, 橡皮筋, 封箱胶带, 橡皮指套, 电线, 酸性玻璃胶, 酒精, 丙酮, 天纳水, 洗板水洗 (溶液含硫化物, 会造成硫化发黑变色)。
- 8、使用环境防潮, 吸水或吸潮会加速度变色和衰减。
- 9、打防水胶要注意, 与 LED 的硅胶的结合情况, 防止硅胶中毒发黑。  
打防水胶时, 如果你盖过了 LED 的胶面, 打胶厚度不均容易产生色差, 选胶匹配。